



Wind 13+

Manual

Installation

Operation

Maintenance

Index

Index	26
Welcome to the world of the wind	27
Wind Turbine Components	29
Datasheet	30
Placing your wind turbine	32
Installation	32
The Tower	33
Electrical wiring	35
Installing the Wind Turbine	36
Maintenance	41
Frequently ask questions	43
Annex	45
Declaration of conformity	47
Warranty	47

Welcome to the world of the wind



Valued Customer,

We want to thank you for purchasing your new Wind 13+ wind turbine and we hope it will meet all the needs for which you have acquired it and for which we have produced it.

Warranty conditions are located at the end of this manual. They are dependent on the proper installation of your wind turbine as this will ensure the correct functioning of the apparatus and, of course, correct servicing.

We are fully available for consultation should you need any type of information about your wind turbine or its installation.

Once again, we welcome you to the World of the Wind.

Most sincerely

Bornay Wind turbines



Interesting information

In this manual you will find all the information needed to install and maintain your wind turbine. We strongly recommend that you read this manual thoroughly and understand it before beginning assembly.

At several points in this manual you will find special notes highlighted. These notes are to be observed with special care because they have critical importance. Please pay special attention to those points marked with the following example notices:

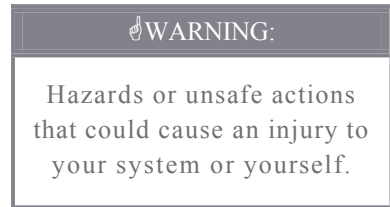
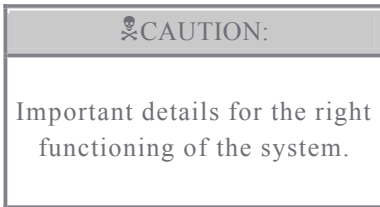

Identification

Each wind turbine is labeled with its model, voltage and serial number data as it follows:

- Manual: Labeled on the cover of this manual.
- Alternator: The wind turbine model, voltage and serial number can be found on the face of the alternator housing above the brushes cover.
- Regulator: On the right side of the control box, there is a sticker indicating the characteristics, regulator model, wind turbine model, voltage, and serial number.

Keep a note of your serial number as this will be useful when you have to order replacement parts and ask for technical assistance.

Wind Turbine Components

Next to this documentation, in the original box, you will find the components listed below. Some items may already assemble:

- 1 Tail
- 1 Tail tube
- 1 Nacelle
- 1 Alternator
- 1 Hub
- 2 Blades
- 1 Frontal cone
- 1 Set of bolts
- 1 Fixation plate

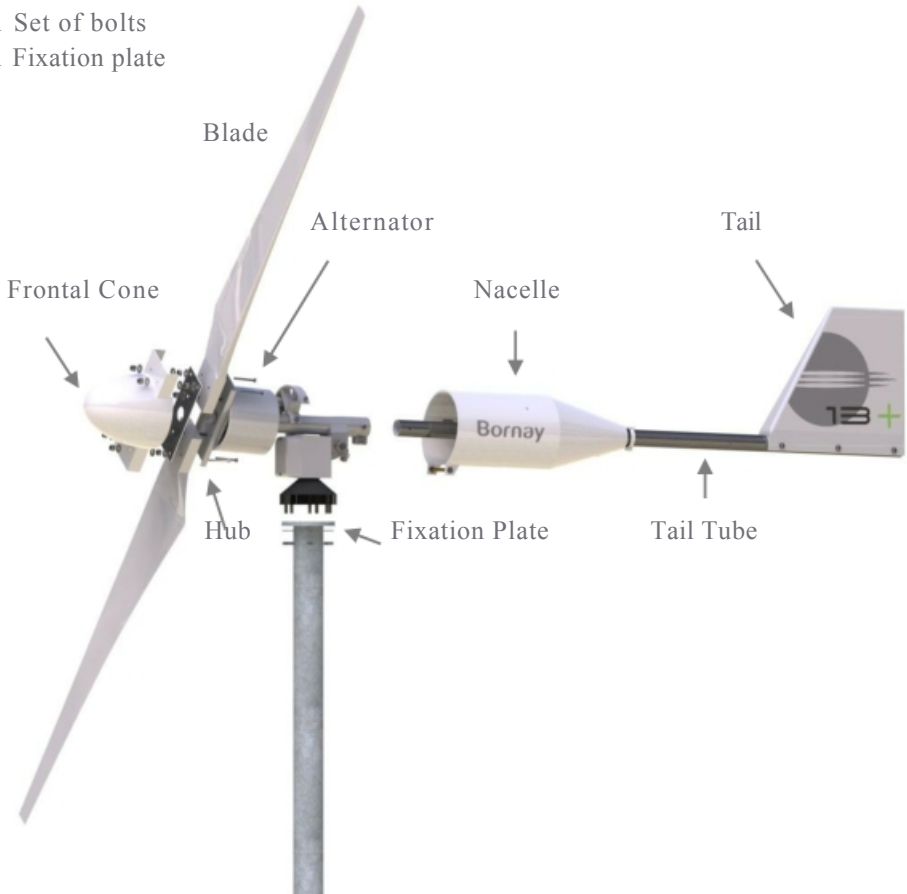

Datasheet

Technical specifications	Wind 13+	Wind 25.2+	Wind 25.3+
Number of blades	2	2	3
Diameter	2,86 m	4,05 m	4,05 m
Material	Fiberglass / Carbon Fiber		
Direction of rotation	Counterclockwise		

Electric specifications

Alternator	Three phases permanent magnet		
Magnets	Neodymium		
Nominal power	1500 W	3000 W	5000 W
Nominal voltage	220 v	220 v	220 v
Nominal RPM	600	400	400

Wind speed

Operating range	2 - 30m/s		
Turn on	3 m/s		
Nominal power	12 m/s		
Automatic brake system	14 m/s		
Maximum	60 m/s		

Physical specifications

Wind turbine weight	41 kg	93 kg	107 kg
Package 1 (WT) - Weight	57 kg	135 kg	149 kg
Pack. 1 - Dimensions (cm)	50x77x57	120x80x80	
Pack. 1 (Blades) - Weight	6,8 kg	19 kg	22 kg
Pack. 2 - Dimensions (cm)	153x27x7	220x40x15	260x40x15
Total - Volume	0,23 m ³	0,90 m ³	0,91 m ³
Total - Weight	63,8 kg	154 kg	171 kg

Warranty	3 years		
----------	---------	--	--

Model	A (mm)	B (mm)	C (mm)	D (mm)	E (mm)
Wind 13+	1430	1670	370	470	2040
Wind 25.2+	2000	2140	470	645	2610
Wind 25.3+	2000	2640	495	645	3135

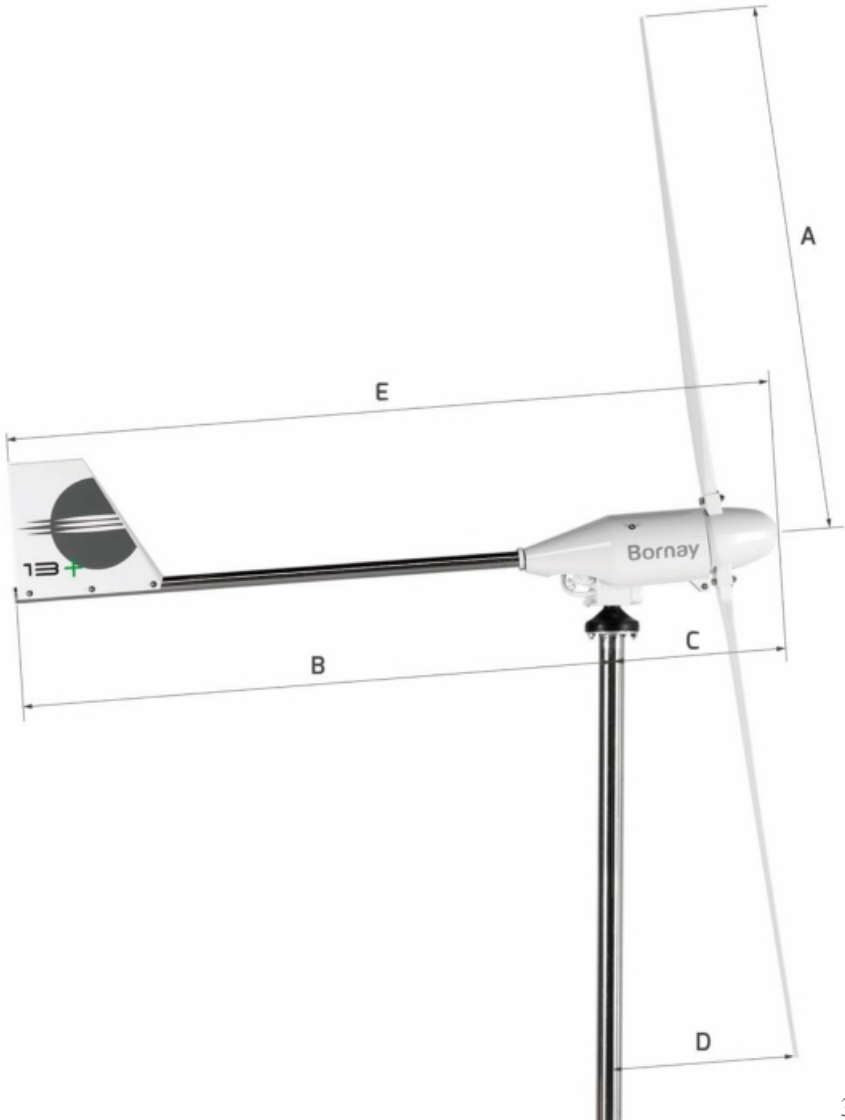

Placing your wind turbine

The best site to install a wind turbine will be a place where it is exposed to the most constant and highest wind speed possible. Wind speed depends enormously on the landscape the air moves over. In almost all locations the wind speed increases, as you get higher off the ground; vegetation, landscape, nearby buildings, etc. stop the wind and produce turbulences.

⚠ CAUTION:

For more information on obstacles affecting wind turbines, see Annex 2.

The best place for a wind machine, is an obstruction-free area, and at the maximum height available.

Installation

Before you begin, run through the steps to follow in order to correctly assemble your wind turbine and take a series of important precautions.



The precautions to follow should be:

- Don't plan to carry out installation on windy days.
- Do not leave the generator running freely. With the generator running freely, the automatic leaning brake system does not work; this could cause irreparable damage to the wind turbine.
- Use the correct wiring.

The Tower

It is recommended to install the wind turbine on an Independent tower, and not next to the house to avoid turbulences.

Anchoring the tower is carried out according to the type for installation, and must be fixed securely to the ground, normally with concrete foundations. It must be totally vertical and leveled to avoid poor wind turbine functioning.

 CAUTION:
Check constantly to ensure that the tower is vertical and level.

In the case of shorter-based towers requiring tensile guy cables: once the base is anchored and the tower is in place, 3 or 4 tensile guy cables are applied, their supports firmly anchored to the ground, generally in concrete foundations.

Check at all times that your tower remains perfectly vertical.

The guys ropes have to absorb all tower bend in windy conditions. Therefore, they must be 6-10 mm diameter steel cables. Attach the guy wires to the highest point of the tower but always beneath the diameter of the blades.

Grounding the tower will provide static and lightning protection for the system. This can be made by driving cooper wire into the ground near the tower base and connecting it to the tower with wire.

We don't recommend the installation of lighting arrestors near to or within the area occupied by the wind turbine.

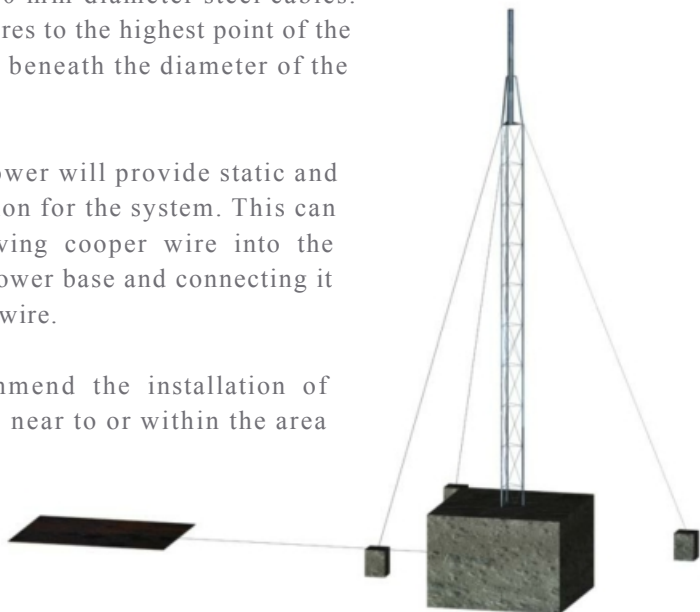

CAUTION:

Wind turbine must be able to turn 360° freely with no obstacles in its way.

WARNING:

Any object touching the blades in movement, will break them and will unbalance the system causing major problems

Once the wind turbine has been installed on the tower, check that it can turn freely and that there are no obstacles within the diameter of the blades.

Under wind pressure, the blades can have up to 15cm of torsion, so there must be a minimum distance of 20cm between the blades and the nearest point.

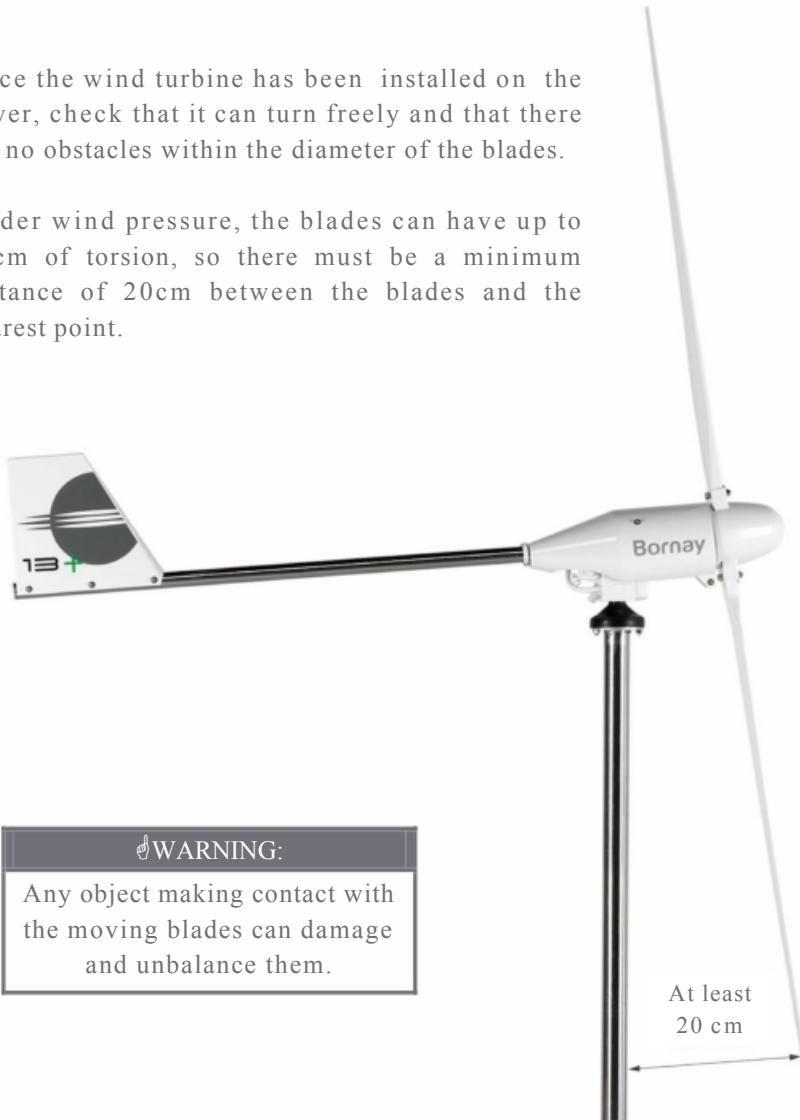

WARNING:

Any object making contact with the moving blades can damage and unbalance them.

Electrical wiring

Full electrical wiring installation must be carried out prior to the installation of the wind turbine and once the tower has been installed.

⚠CAUTION:
Never install the wind turbine if the regulator and batteries are not properly connected..

⚠WARNING:
Never invert polarity.
Use appropriate sized cables.

The first step in the electrical configuration is to place the correct battery bank, with its correct connection configuration and connected according the manufacturer's specifications, thus obtaining the right voltage and capacity for the installation to be carried out.

Different types of batteries exist. In the case of domestic hybrid wind energy/solar energy installations, open lead-acid batteries are recommended and, to meet the installations charge capacities, certain minimum installation requirements are essential to assure correct running and durability of the installation.

The minimum installation recommendations and battery-to-regulator cable recommendations are the following:

Model	Battery Cable	Minimum Battery
Wind 13+ / 220V	10 mm ²	150 Ah C ₁₀₀
Wind 25.2+ / 220V	16 mm ²	250 Ah C ₁₀₀
Wind 25.3 +/ 220V	16 mm ²	550 Ah C ₁₀₀

⚠CAUTION:
The use of stationary open lead-acid batteries is recommended.

⚠WARNING:
Use of the wrong battery can cause irreparable damage to your wind turbine.

Installing the Wind Turbine

Before assembling the wind turbine on the tower, the electrical installation must be completed, as well as the interconnection between batteries and regulator.

Once we have the electrical wiring installed, we will proceed to assemble the wind turbine.

To ease installation of the wind turbine on the tower, a bracket and pulley system should be used.

This system must securely attach to the tower, with the pulley on top.

Using this method, the turbine can be hoisted up and secured while the electrical connection is completed and the turbine is fitted to the tower.



Fixation plate

This plate is provided to be attached to the tower. Another one is assembled on the wind turbine base.

Its function is to secure wind turbine, offering an ease of installation and removal from the tower at any moment.

The plates are made with slots to allow the cables to pass through without twists. They are attached with Allen bolts and six holes are provided for six M10x40 Allen bolts, with M10 washers on both faces and six M10 nuts. The bolts set and tower plate are served in an independent plastic bag, if not mailed before.

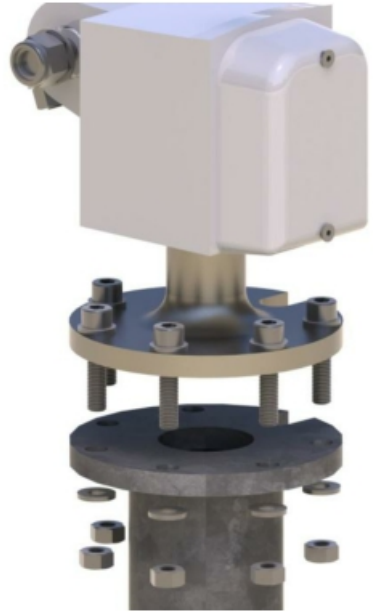

Tail / Tube tail

The tail is made to keep the wind turbine facing into the wind at any time.

The tail is made of two different pieces: a polyethylene vane and a steel boom. They are put together with three M6x80 bolts, six wide-series M6 washers on both sides of the vane, and three M6 self-locking nuts.



Tail tube / Alternator

The tail is attached to the alternator at this point. Before bolting the tube to the alternator, pass the protective casing through the tail tube. (Once the tube is bolted, you will not be able to install the casting).

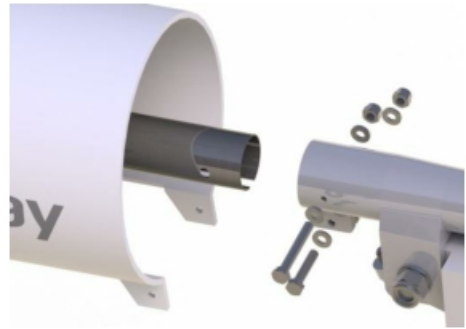

This joint has two different systems to secure, one has a bolt going through the tube, and the other one is a flange system. We first introduce the tail tube into the back side of the alternator, and match the holes in both pieces. We use now a hexagonal M8x60 bolt, with two M8 washers, one in each side and an self-locking M-8 nut. Tighten both to 2,5 Kg.

Nacelle

The nacelle protects the alternator from external climatologically agents. The nacelle is attached with four bolts; two of them are on upper part, one is on the back with a clamp, and the last one goes in the flange on the lower frontal section:

On the top of the nacelle there are two holes ready for two M6x15 bolts with their correspondent wide series M-6 washers and a grover washer, directly bolted to the alternator bridge. The assembly order is: bolt, grover washer and wide washer.

Next, the clamp bolt must be tightened at the back part of the nacelle.



Finally, on the lower front side, using the two flanges to anchor, we insert the brass tube (102 mm long x 10 mm exterior diameter), one M6x120 bolt, with an M6 wide series washer on each side, on the inner side of the nacelle between the two flange-forming flaps. Finally, secure using a washer and auto-blocking nut.

Blades and Frontal cone

The blades, made reinforced carbon fiber/glass make direct contact with the wind. They are highly stressed. Their aerodynamics, specifically designed for Bornay wind turbines, makes the alternator turn faster or slower depending on wind speed.

Blade assembly is carried out by securing them to the hub, with the relief logo towards the rear part, i.e. facing the alternator.

The two external bolts will be M10x55, while the central internal bolt - now installed - is M10. Once installed, the blades must be adjusted.

Without using any nuts or washers, the aluminum hub reinforcement layer is assembled, and this will give the assembled parts more solidity. To secure this reinforcement we use wide-series washers and normal M10 nuts into the two internal bolts. With the help of a dynamometric Allen key, these two nuts must be initially tightened to 2 kg. Once tightened, both nuts must then be retightened to 2.5 kg.

The next step, having retightened both all nuts, is to insert the frontal nose cone into the four external bolts. Once installed, another wide-washer and M-10 self-blocking nut are applied. With the help of a dynamometric Allen key, these two nuts must be initially tightened to 2 kg. Once tightened, both nuts must then be retightened to 2.5 kg.

Observe the next illustrations carefully.

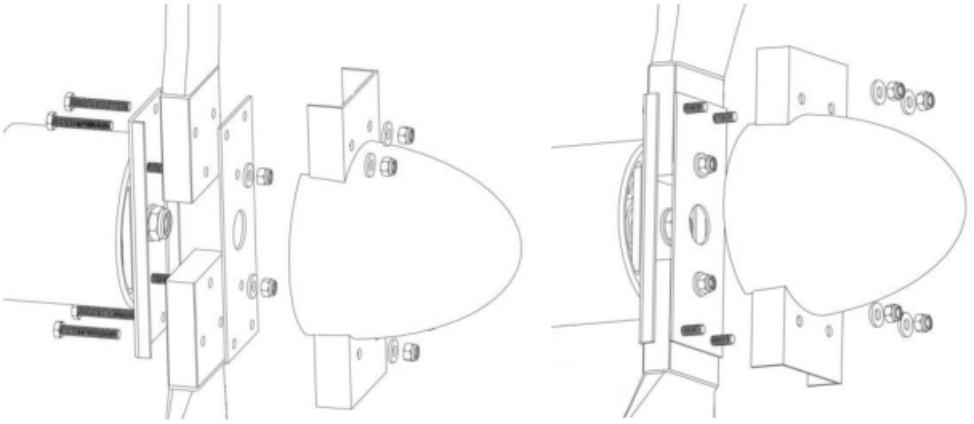

⚠ CAUTION:

Double check that blades fit perfectly and that no obstacle will get in their way.

👉 WARNING:

Check blades are correctly mounted in the right place; the Bornay logo must be to leeward, on the reverse side

👉 PRECAUTION:

- Do not manipulate the wind turbine and its control panel on windy days.
- Do not leave the wind turbine run freely (disconnected from the batteries), this could damage the charging system. If you need to disconnect the wind turbine from the batteries, always brake it.
- With the wind turbine turning freely, the automatic breaking system does not work, that could cause irreparable damages in your wind turbine.
- Do not manipulate the loads in the regulator.
- Do not invert the polarity in any case.
- Use the appropriate wiring.

Maintenance

After the installation

One month after the installation of the wind turbine, we recommend checking that the bolts have the right torque and tightening, if necessary.

Periodic maintenance

To ensure long life for your wind turbine, we recommend the following maintenance schedule:

Each 6 months

If possible in the station changes, it is recommended to carry out a maintenance inspection in which the following points should be checked:

- Checking and readjusting the torque required for every bolt.
- Checking state of wiring.
- Visual inspection of blades.
- Checking that the automatic breaking system works properly by tilting it manually.

The main wind turbine parts for maintenance inspections are:

Bearings

Bornay wind turbines are equipped with great quality sealed bearings which require no maintenance. You can check to see if they turn freely or if the opposite occurs and some kind of friction or vibration is observed.

Bolts

The bolts used in Bornay wind turbines are stainless steel. If a bolt is missing or in poor condition, it must be replaced right away in order to avoid any breaking or further damage.

Wiring

All cable connections and switches must be properly checked in order to prevent any disconnection and to allow the wind turbine to run freely.

Blades

The reinforced carbon fiber/glass blades are covered by a protective tape made of abrasive polyurethane on the leading edges of the blades.

After years of use, this tape may be affected by weather conditions. If the tape is missing or partially missing, contact your local installation office to have the tape replaced. By failing to replace the tape, the life of the blade will be seriously reduced due to the strong erosion the blade is exposed to.

Shock absorber

The wind turbine has one hydraulic shock absorber installed that prevents abrupt shocks by promoting fast braking and slow return to its original position.

The shock absorber has a little slack at the beginning of its return movement, and this is normal. However, if this slack is observed to continue for over half the return movement, and if oil is leaking, the shock absorber must be replaced.

Lubrication

Wind + wind turbines have three moving parts:

The front shaft (blades-alternator) is equipped with sealed bearings and covered with lubricant. It does not need any special attention; its lubricant will last during its lifetime.

The yawing shaft (wind turbine-tower) is equipped with sealed bearings and covered with lubricant. It does not need any special attention; Its lubricant will last during its lifetime.

The alternator shaft (alternator-yawing system) is a stainless steel tube covered with lubricant. It does not need any special attention. Its lubricant will last during its lifetime.

Frequently ask questions

1.- Can battery polarities be changed?

No, this would cause the regulator to break down.

2.- ¿How can I find out what energy the wind turbine is providing?

The energy can be known through the screen or with the specific software of Bornay.

3.- Could the drilled holes in the blades be bad?

No, each wind turbine is assembled completely in production. If the drilled holes do not match up, try turning the blades round the other way. Some models have 3 and some have 5 holes drilled, and one of these is slightly off centre in order to define correct blade installation.

4.- Will one of these wind turbines provide enough power for a home?

This kind of wind turbine is normally used together with other components to form a complete installation. These components are usually:

- Solar panels: energy production.
- Solar regulators: to control battery charge from the solar panels.
- Batteries (accumulation of this energy): These installations are normally designed to give three full days of independence, in other words they can supply the installation for three days without sun or wind. They use direct current.
- Wind regulator: This is included with the wind turbine and this is what controls battery life. It ensures that battery voltage does not surpass dangerous levels. At the same time, it will brake the machinery when this does occur.
- Inverter/Charger: This is the equipment that transforms direct current from batteries into alternating current for consumption (230V).
- Back-up generator: In remote installations, this is installed to guarantee complete independent functioning of the installation.

Normally, the inverter handles the start-up and stopping on the motor according to installation needs. For example, if the battery runs the inverter will order the motor to start.

5.- Can several wind turbines be set up in parallel?

Yes, several wind turbines can be run in parallel.

6.- What kind of power is generated by the alternator?

The wind turbine generates an alternating three-phase signal with a nominal voltage of approximately 230V.

7.- Should some protection be installed between the wind turbine and the regulator or between the regulator/interface and the battery?

No, never. The regulator/interface is already carrying out these protective functions.

If you were to install intermediate protection and this disconnected the electrical connection, the wind turbine would lose its charge and this could cause irreparable damage to the wind turbine or the regulator/interface.

8.- Should an auxiliary brake switch be installed?

It is not necessary, but it may be advisable in the installations where you want to stop the wind turbine completely, in order to make some intervention in the equipment.

Annex

Annex I.- Wind types

Beaufort's table is the international reference to classify and define the wind depending on its speed.

Force	Wind speed (m/s)	Wind speed (km/h)	Denomination
0	0 - 0.5	0 - 1	Calm
1	0.6 - 1.7	2 - 6	Light air
2	1.8 - 3.3	7 - 12	Light breeze
3	3.4 - 5.2	13 - 18	Gentle breeze
4	5.3 - 7.4	19 - 26	Moderate breeze
5	5.7 - 9.8	27 - 35	Fresh breeze
6	9.9 - 10.4	36 - 44	Strong breeze
7	12.5 - 15.2	45 - 54	Near gale
8	15.3 - 18.2	55 - 65	Gale
9	18.3 - 21.5	66 - 77	Strong gale
10	21.6 - 25.1	78 - 90	Storm *
11	25.2 - 29	91 - 104	Violent storm
12	More than 29	More than 104	Hurricane

* On receiving strong storm warnings, Bornay recommends manually braking equipment in order to protect the wind turbine.

Annex 2.- Landscape and objects that influence on wind turbines

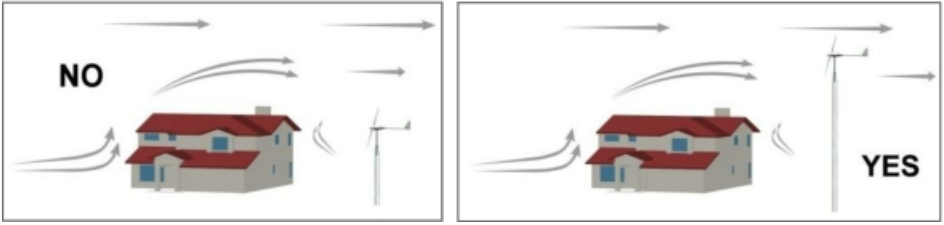

When the wind is eclipsed by the objects it finds in its way, it reduces its speed and turbulence results. The performance of a wind turbine installed on the wrong location will be adversely affected by turbulence and light winds.

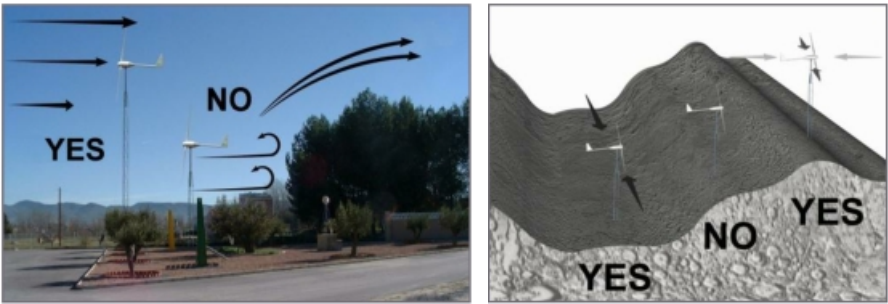

To maximize the performance of your wind turbine, it should be installed as far as possible from the obstruction and atop a tower higher point from this obstacle.

If the wind turbine is going to be installed in a valley, it should be at the lowest point where the wind is channeled and freely flowing, or at the highest peak of the valley, where it can capture wind moving in any direction.

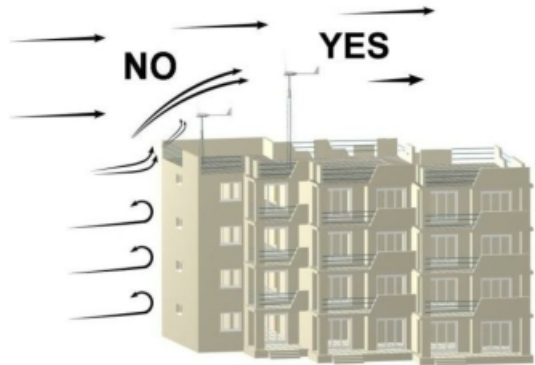

Declaration of conformity



Mr. Juan Bornay Rico, on behalf of and representing Bornay Aerogeneradores, slu,

STATES

That Bornay wind turbine models Wind 13+, Wind 25.2+, Wind 25.3+ and their corresponding regulators, have been produced in compliance with regulations applicable under the E.U. directives:

89/392/CEE

91/368/CEE

And in accordance with the safety regulations for small wind power turbines:

UNE-EN-61400-2

Castalla, May 1, 2017

A handwritten signature in blue ink, appearing to be "Juan Bornay Rico". The signature is stylized and somewhat abstract, with overlapping loops and lines.

Signed: Juan Bornay Rico.

Bornay Aerogeneradores SLU

P.I. Riu, Cno. del Riu, s/n
0320 Castalla (Alicante) España

Tel. +34/965560025
Fax +34/965560752

bornay@bornay.com
www.bornay.com

ENG

Warranty

LIMITED WARRANTY

Your new Wind + wind turbine is guaranteed against any material defect. This warranty does not include other equipment or accessories that could be involved in repairing the wind turbine. The warranty does not cover defects or damages produced by improper use or installation of the product.

WARRANTY PERIOD – WIND + WIND TURBINES

The warranty period for the Wind + wind turbines and their components is 36 months from date of original installation or 40 months from fabrication date.

WIND + WIND TURBINES ACCESORIES

The warranty period for the Bornay accessories is 36 months from date of original installation or 40 months from fabrication date.

WARRANTY CONDITIONS

The Warranty covers parts and labour in our workshops only. The wind turbine must be returned suitably packaged and at the buyer's expense.

The Warranty does not cover breakage due to incorrect usage or equipment with signs of manipulation. Shipping is not covered by the Warranty.

Bornay reserves the right to substitute or modify any part should the case call for such.

Any wind turbine not meeting these conditions will be repaired and shipped at cost to buyer, with prior authorization from the customer.